



## Programming

EduArmBot-250 is controlled by the Robotic Control Software, supplied free with the robot. Full command protocol is also supplied for software developers who wish to control EduArmBot-250 from their own control software.

Control Software features include: -

- The robot can be controlled either manually or through a program sequence.
- All analogue/digital input and digital output states can be observed constantly and controlled by a mouse click on the screen.
- Different configuration settings for different applications can be created for immediate recall, i.e. servo limits, park position, labels, operational mode, etc.
- The robot is programmed by the use of easy-to-use and efficient single-character commands.
- Programming can be carried out in either Design Mode or Record Mode. In Record mode, any change you make on the screen controls is automatically inserted in the text box as program code. You may also edit and save these entries in Design Mode.
- A comprehensive Help Menu is incorporated within the software.

## Specification

<b>Degree of freedom</b>	6
<b>Load Capacity</b>	1kg
<b>Vertical Reach</b>	595 mm
<b>Horizontal Reach</b>	480mm
<b>Repetitive Accuracy</b>	+/-0.5 mm
<b>Motion Range</b>	Waist 180° max 175° nominal Shoulder 180° max 175° nominal Elbow 180° max 175° nominal Wrist Roll 180° max 175° nominal Wrist Pitch 180° max 175° nominal
<b>Arm Weight</b>	5kg
<b>Controller Servo Channels</b>	8 (5 x axes + 1 x gripper + 2 x spare)
<b>Digital Inputs</b>	4, Vinmax = +5.0VDC
<b>Analogue Inputs</b>	2, Vinmin = 0VDC, Vinmax = +5.0VDC
<b>Digital Outputs</b>	3, Voutmin = 0VDC, Voutmax = +5.0VDC
<b>Serial / USB Communication</b>	Via USB / RS-232 Serial Port
<b>System Requirements</b>	Operating System: Windows 95,98, NT4, 2000, XP. Processor: 486/100 or above (Pentium recommended). Memory: 16MB min, 32MB recommended. Occupied Disk Space: 2.5MB

## Dimension

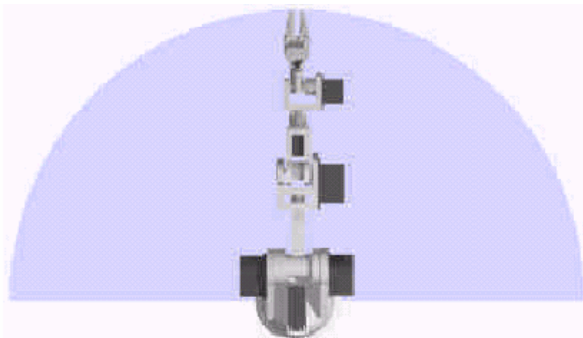

Top- View

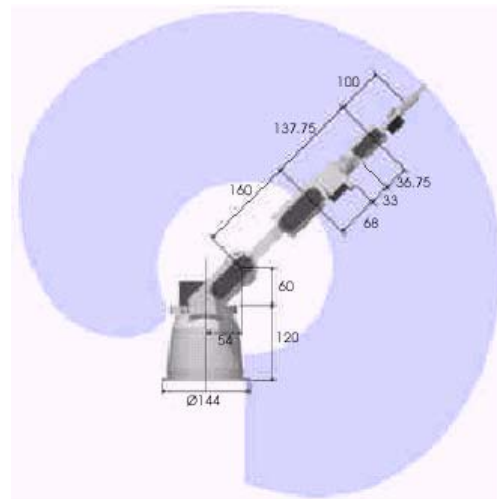

Side-View

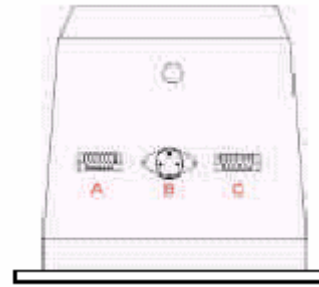
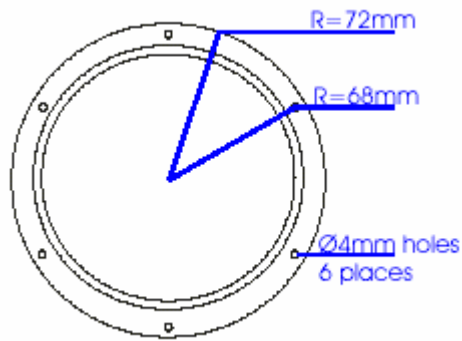

## Interfacing



15-Pin D type Socket  
Interface



3-Pin DIN Socket  
Power



9-Pin D type Socket  
RS232 serial

## Optional

### Computer

- Operating System: Windows 95, 98, NT4, 2000, XP.
- Processor: 486/100 or above (Pentium recommended).
- Memory: 16MB min, 32MB recommended.
- Occupied Disk Space: 2.5MB

## OVERALL



- 6 Axis Articulated Educational Robotic Arm (extra 2 axis spare)
- Connects to the USB / serial port on your PC and is controlled via control software.
- Body and gripper are made from acetal, arm links are made from anti-static PVC.
- All axes are driven by R/C servo motors.
- Fully modular arm can be mounted onto mobile vehicles or used as stand-alone.
- Can easily be interfaced with other robotics / control system.
- Gripper or suction cup end effector.

## Curriculum Cover

- Introduction of PC based robot system
- Introduction of 6 degrees of freedom robot
- Introduction of application for the grippers
- Interfacing with external electronic circuit by using the electronic components and the extra analog and digital I/Os provided
- Introduction of robot programming
- Robot system controlled either manually or through a program sequence
- Interfacing between the controller and the PC
- Introduction of motion control
- Fully addressable and up to four robots can be controlled from one PC

## Training

Type : On- Site Instruction Training & Commissioning  
Duration : 1 working day  
Total person to be trained : Unlimited

## Warranty

One year against manufacturing defect